

MODEL E-1800 XLT HOT TUBE

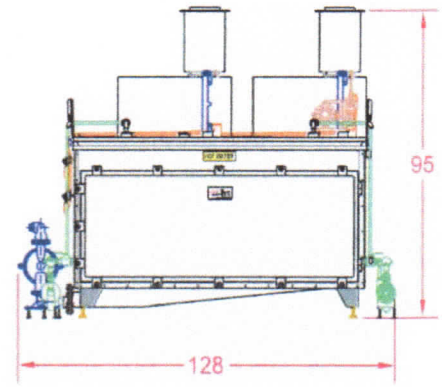

Physical Dimensions with burner

Length	287"
Width	128"
Height	95"

Tank Capacity, gallons

maximum	2,800
nominal	1,800

Weight, pounds
empty _____

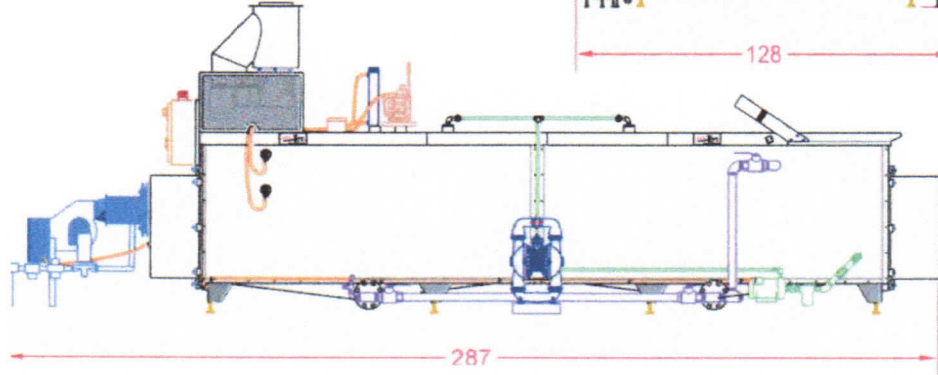

Evaporation Rate E-1800 XLT Hot Tube -- 400 gallons per hour

(Evaporation rate varies with the nature of the waste solution and input of BTUs.)

LAKEVIEW E-SERIES WASTEWATER EVAPORATOR

POWER REQUIREMENTS

FUEL REQUIREMENTS -- natural gas or propane, minimum 10" w.c., 1-1/2" line

BTU INPUT MAXIMUM -- 4,800,000 BTU/hr @ 400 gph

ELECTRICAL REQUIREMENTS -- 240/480v, 3ph, 20 amps @ 480v

COMPRESSED AIR -- 40-100 psi maximum, 8 scfm maximum for filling

STANDARD SPECIFICATIONS/FEATURES

- Tank construction -- 10 gauge, 316L stainless steel construction
- Heat exchange tube -- 10 gauge, 316L stainless steel construction
- Access and blower lid -- stainless steel for all wetted parts
- Insulation -- 2" foil backed, 850°F, .30 conductivity, .043 SI units
- Exhaust blower housing -- heavy gauge, tig welded stainless steel
- Impeller -- self-cleaning backward inclined radial blade design
- Stack connection -- 14" I.D. flanged connection, two
- Blower motor -- 3 hp, 3ph, 2450 rpm, two
- Power burner -- two (2) forced draft burners, FM rated with full modulation
- Fluid transfer pump -- air operated diaphragm pump, 1" FPT
- Control panel -- NEMA 4 rated enclosure, industrial duty, touch panel, PLC
- Fluid level control -- float actuated ball valve
- Fluid level sensors -- float actuated microswitches, high/low level
- Coalescing filter -- framed stainless steel mesh at blower inlet
- Clean out -- 4" flange with eccentric reducer at 2" FPT
- Weir -- built in for easy skimming of floating oils
- Belt driven blower -- eliminates transference of vibration and heat
- Pillow block bearings -- heavy duty, greasable for long life

WARRANTY

Five (5) year limited warranty on water vapor blower impeller, the most used part of the evaporator. It is indicative of the quality and durability built into the complete unit. The entire evaporator carries a two (2) year limited warranty. See *Terms and Conditions of Sale and/or Warranty Certificates.*

OPTIONAL FEATURES

- Special tank/tube construction
- Double wall stacks
- Remote fluid level sensors
- Overspray foam control
- Automation package
- Skimmer/sludge pump
- Remote tank oil sensing
- Power wash clean out ports
- Rectangular clean out

STANDARD SAFETY FEATURES

- Industrial safety disconnect at the unit
- Air-cooled, counterweighted access lid
- Safety circuitry and manual reset
- Flame safety monitoring burner flame
- Safety cage around hot moving parts
- Fluid temperature monitor
- Heat exchanger temperature monitor
- Redundant safety and level controls

LAKEVIEW ENGINEERED PRODUCTS INC

2500 W Jefferson Blvd, Fort Wayne IN 46802

tel: 260-432-3479

fax: 260-432-6239

www.lakeviewengineered.com

info@lakeviewengineered.com

NOTE: Evaporators should not be used with fluids that have a boiling point lower than water, contain volatile organic compounds or contain flammable materials.