

MODEL E-1200 XLT HOT TUBE

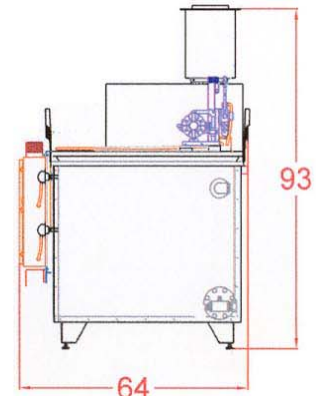
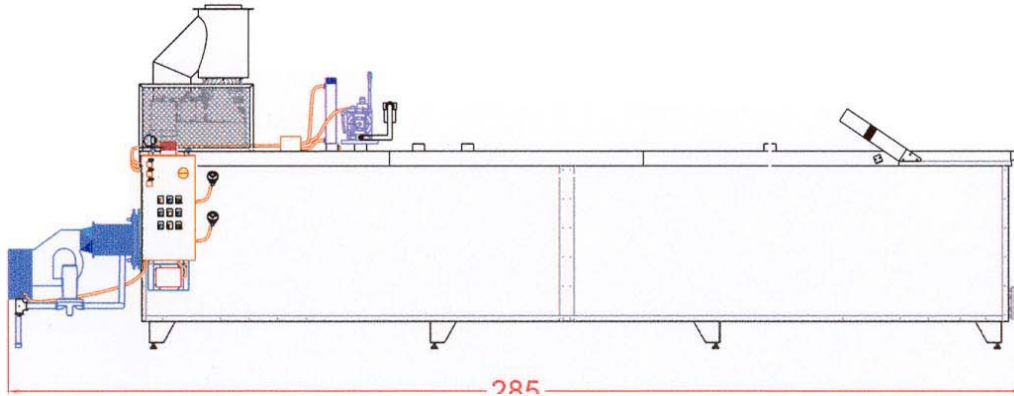

Physical Dimensions with burner

Length 285" Height 93"
Width 64"

Tank Capacity, gallons

maximum 1,885
nominal 1,200

Weight, pounds

empty 4,250

Evaporation Rate E-1200 XLT Hot Tube -- 200 gallons per hour

(Evaporation rate varies with the nature of the waste solution and input of BTUs.)

LAKEVIEW E-SERIES WASTEWATER EVAPORATOR

POWER REQUIREMENTS

FUEL REQUIREMENTS -- natural gas or propane, minimum 10" w.c., 1-1/2" line

BTU INPUT MAXIMUM -- 2,750,000 BTU/hr @ 200 gph

ELECTRICAL REQUIREMENTS -- 240/480v, 3ph, 10 amps @ 480v

COMPRESSED AIR -- 40-100 psi maximum, 8 scfm maximum for filling

STANDARD SPECIFICATIONS/FEATURES

Tank construction -- 10 gauge, 316L stainless steel construction
Heat exchange tube -- 10 gauge, 316L stainless steel construction
Access and blower lid -- stainless steel for all wetted parts
Insulation -- 2" foil backed, 850°F, .30 conductivity, .043 SI units
Exhaust blower housing -- heavy gauge, tig welded stainless steel
Impeller -- self-cleaning backward inclined radial blade design
Stack connection -- 14" I.D. flanged connection
Blower motor -- 3 hp, 3ph, 2450 rpm
Power burner -- forced draft burner, FM rated with full modulation
Fluid transfer pump -- air operated diaphragm pump, 1" FPT
Control panel -- NEMA 4 rated enclosure, industrial duty, touch panel, PLC
Fluid level control -- float actuated ball valve
Fluid level sensors -- float actuated microswitches, high/low level
Coalescing filter -- framed stainless steel mesh at blower inlet
Clean out -- 4" flange with eccentric reducer at 2" FPT
Weir -- built in for easy skimming of floating oils
Belt driven blower -- eliminates transference of vibration and heat
Pillow block bearings -- heavy duty, greasable for long life

WARRANTY

Five (5) year limited warranty on water vapor blower impeller, the most used part of the evaporator. It is indicative of the quality and durability built into the complete unit. The entire evaporator carries a two (2) year limited warranty. See *Terms and Conditions of Sale and/or Warranty Certificates*.

OPTIONAL FEATURES

Special tank/tube construction
Double wall stacks
Remote fluid level sensors
Overspray foam control
Automation package
Skimmer/sludge pump
Remote tank oil sensing
Power wash clean out ports
Rectangular clean out

STANDARD SAFETY FEATURES

Industrial safety disconnect at the unit
Air-cooled, counterweighted access lid
Safety circuitry and manual reset
Flame safety monitoring burner flame
Safety cage around hot moving parts
Fluid temperature monitor
Heat exchanger temperature monitor
Redundant safety and level controls

LAKEVIEW ENGINEERED PRODUCTS INC

2500 W Jefferson Blvd, Fort Wayne IN 46802

tel: 260-432-3479

fax: 260-432-6239

www.lakeviewengineered.com

info@lakeviewengineered.com

NOTE: Evaporators should not be used with fluids that have a boiling point lower than water, contain volatile organic compounds or contain flammable materials.

"Hot Tube"[®] E-Series Wastewater Evaporator Natural Gas/Propane - standard features



POWER BURNER -- FPG

Forced draft burner for positive combustion that maintains efficiency by minimizing the effect of air pressure changes around the evaporator. A power burner is the highest efficiency and most reliable burner that can be utilized on industrial equipment. Standard burners are manufactured to U.L./CSD-1 requirements.

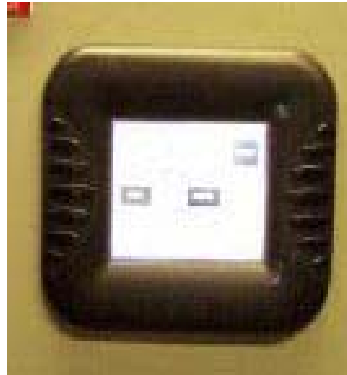

CONTROL PANEL

Industrial duty panel with NEMA 4 rated enclosure. Operational controls include PLC controller, touch panel display and operator interface, heat exchanger temperature monitor, high/low level controls, tank fluid temperature sensor. Panel also utilizes a standard safety disconnect and red flashing warning beacon. Optional features may include-- digital read out and controls for overspray foam control, other NEMA ratings, remote panels, PLC automation.



HEAT EXCHANGER TUBE (standard)

Polished, large diameter, tubular 10 gauge, 316L stainless steel standard construction (other alloys available), reducing diameter over tube length to maintain scrubbing velocity for high efficiency. Tig welded, tuned for high heat transfer efficiency and designed for ease of cleaning and tank bottom access. Exiting tube section is shrouded to prevent fluid surface fouling.



XLT HIGH EFFICIENCY TUBE (optional)

Extended length burner tube to provide a greater square feet of heat transfer surface. This results in lower stack temperature, more efficient utilization of energy and increased evaporation capacity, as much as 50% higher than normally advertised rates within the same footprint. Energy consumption per gallon evaporated is reduced by up to 20% with the addition of this option. Wastewater analysis must be performed to qualify application. Available on E-300 and larger models.



TANK

The entire unit, both interior and exterior, including all wetted internal parts are constructed of polished stainless steel. Polished stainless steel outer skin, when properly maintained, looks like new indefinitely. *Standard construction for all units* -- 10 gauge (.140") grade 316L stainless steel - offers excellent resistance to a wide range of corrosives and atmospheric exposures, high temperature strength. All sides are insulated with 2" fiberglass, 800°F rated. Tank bottom is sloped to 4" flange clean out port for easy solids evacuation. Alloy recommendation does not express or imply any warranties offered against material corrosion.

TANK AND HEAT EXCHANGER CONSTRUCTION OPTIONS

- AL6XN - 6% molybdenum super austenitic alloy for better chloride resistance without the expense of high nickel alloys.
- High nickel alloys - such as B-2, C-22, G-30, 20Cb-3 for a wide range of specific corrosive applications.
- Hastelloy C-276 - one of the more universally corrosion resistant alloys with excellent high chloride resistance and high temperature properties.

“Hot Tube”® E-Series Wastewater Evaporator Natural Gas/Propane - standard features

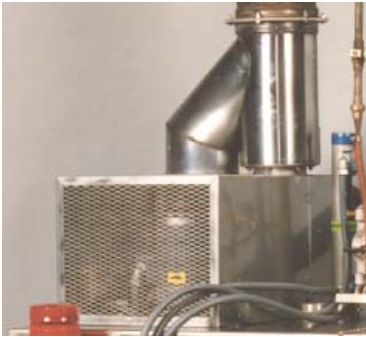

Y-SECTION

Two-in-one double wall stack connection to separate effluents (see stack description).

BLOWER GUARD

A safety cage surrounds the blower, blower motor, drive belt, and stack. This protects personnel from heated and moving parts.

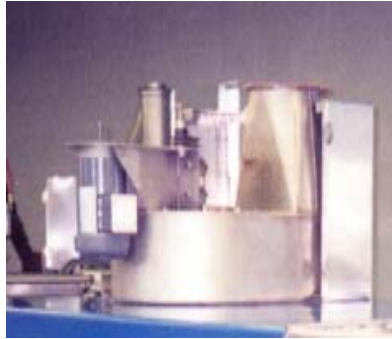

EXHAUST BLOWER

Designed specifically for evaporated vapor exhaust. This blower features an all stainless steel impeller with 5 year warranty. The impeller is self-cleaning backward inclined radial blade design that is electronically balanced for long continuous duty. It is belt driven with self-adjusting belt tensioner and speed variable depending on model application.

Two heavy duty, greasable pillow block bearings are utilized. The blower housing is all heavy gauge, tig welded, stainless steel construction for long life.



ACCESS LID

With exhaust air inlet - keeps lid cool to the touch. Lid is counter-weighted for operator safety.



OIL SKIMMING WEIR

The oil skimming weir drains through a 2" port located at the right height for a barrel, or piping can be easily installed to direct the oil to a destination. The flat sloped bottom is designed for easy cleaning. No complicated bottom geometry to create cleaning problems.

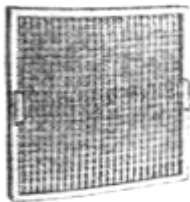

COALESCING FILTER

Located at the inlet to the water vapor exhaust blower to capture droplets that might be drawn up the stack. This is to minimize carry over of oils or particulates to the atmosphere. It is easily removed for cleaning or replacement when dirty. High density mist eliminator pads are also available.

CLEAN OUT PORT

The 4" NPT clean out port is located at the low point of the flat, sloped bottom for easy clean out. Both the oil skimming weir and clean out port may be connected to the skimmer sludge pump option with the 2" NPT reducer provided.



TRANSFER PUMP SYSTEM

Fluid level control is maintained by a float operated ball valve. The transfer pump is air operated to pumps fluid from a storage tank to the evaporator. When the fluid level is low in the evaporator, the pump forces fluid through the valve, as the fluid level rises the float ball rises on the surface of the fluid closing the valve. When the tank is full, the air pump stalls against the closed valve. Fluid level, by this method, is maintained at a constant level without larger volumes of wastewater introduced into the evaporator to cool and upset the fluid already in the tank. This results in efficient steady-state operation.



LEVEL CONTROLS

Redundancy level control is achieved by the use of a stainless steel lever-arm float valve assembly and a high/low level float switch assembly. The float valve assembly provides stable continuous feed into the evaporator, while the high/low level float switch monitors fluid level extremes and will shut down the burner, feed pump and indicate an alarm fault condition. Surface operating floats ignore foam and are not affected by fouling fluid concentrations or temperatures. The level switch also allows for fill control upon start up and auto restart.

"Hot Tube"® E-Series Wastewater Evaporator Natural Gas/Propane - additional options



DOUBLE WALL STACK

(recommended) Stack within a stack that exhausts water vapor through the inner stack and the burner exhaust through the outer stack, venting to the outside atmosphere. This prevents water vapor from condensing and drifting. Stacks bolt together in five (5) foot sections with die cut high temperature gaskets. Double wall stacks also help minimize odors that may be created when exhaust gases are combined with water vapor.



OVERSPRAY FOAM CONTROL SYSTEM

Electric operated centrifugal pump that recirculates fluid from the evaporator and sprays it over the surface of the liquid waste. This helps to break up surface tension and allows the water to evaporate through any surface film. It also exposes more surface area to the air being pulled across the surface of the fluid assisting in the evaporation rate. Foam sensor

operates in the area above the normal operating fluid level and detects foaming conditions as they occur in the tank. This sensor then activates the overspray system. All components, pump, strainers, nozzles, valves, piping, and controls are included. Assembly is stainless steel for all wetted parts.

HOLDING TANK

HDPE, polypropylene, steel, or stainless steel. Many standard and custom engineered designs and sizes available. Connections, sight glass, manways, control interface, stainers, skimmers, and valves available to suit specific requirements.

ANTI-FOAM DISPENSER

The chemical feed pump will automatically add the anti-foam agent to the waste solution in the evaporator. It operates in conjunction with a foam sensor that detects the presence of foam in the space above the normal operating fluid level in the evaporator tank.

ODOR CONTROL

A pneumatic dispenser releases an atomized chemical adsorbent from a strategic location into the evaporator air stream. Calibrated metering and available electric timer controls allow for tailoring to specific requirements.

SPECIAL APPLICATION, PLC CONTROLS

Remote operating controls or remote telemetry. Consult factory for special automation and monitoring requirements or specific types.

REMOTE TANK SENSING SYSTEM

The feed tank that supplies the evaporator also works as a settling tank and an oil separator tank. Pumping separated sludge or oil to the evaporator will reduce overall efficiencies and require more operator and maintenance time. 1) The feed tank can be set up with sensors to determine oil and sludge layers and permit pumping only aqueous wastes to the evaporator. 2) The feed tank can be set up with level controls to determine presence of fluid and shut down or restart the evaporator according to demand.

FACTORY MUTUAL (F.M.) RATING

Burner controls and gas train set up to comply with F.M. requirements. Standard on larger models.

INDUSTRIAL RISK INSURERS (I.R.I.) RATING

Burner controls and gas train set up to comply with I.R.I. requirements.

PUMP DIAPHRAGMS

Standard transfer pump diaphragm is Santoprene. Other available pumps include Neoprene, Buna N, Viton, T.F.E. (Teflon) with urethane, E.P.R., and Polyurethane.



SKIMMER SLUDGE PUMP SYSTEM

(optional) Transfer and removal of skimmed oils and evaporator residue. Air operated diaphragm pump, 2" NPT, plumbed into clean out and oil skimming weir, all piping and valves for easy operation. Available as 1) aluminum housing, black iron pipe and bronze ball valves; 2) cast iron housing, black iron pipe and stainless ball valves; or 3) stainless steel housing, pipe and ball valves. 1" NPT pumps available for light duty applications. Manual and automated systems available.



REMOTE FLUID LEVEL SENSOR AND CONTROLS

(optional) Adjustable remote level float switch can be tether mounted in any type of wastewater storage vessel and connects to the evaporator control circuit to shut down the evaporator when wastewater supply is depleted and then restart the evaporator when the wastewater supply is replenished. This option requires that the transfer pump and controls are operational.



WATER VAPOR RECOVERY CONDENSER

Condenser will recover the water vapor coming off the evaporator. Each application is individually assessed to determine correct type of condenser based upon flow rate off the evaporator and the availability of cooling medium for the condenser. The water may then be recycled within your facility. Requires cooling medium and may increase your operational costs. We will help you closely assess your needs for this option.

REDUNDANT (BACK-UP) LEVEL CONTROLS

Secondary high and low level control assembly, to be installed as a back-up to the primary high/low level controls. Back-up assembly may be either the same type as the primary (float actuated microswitches), conductivity type or frequency shift sensors.

#2 OIL / DIESEL / HEAVY OIL / WASTE OIL

Combination gas/oil air atomizing burner and modifications to combustion chamber to accommodate the burning of various oils in the evaporator as fuel. Offers versatility in energy sources. Waste oils must meet certain qualification requirements. *This option available only on E-600 and larger models.*

MODULATING GAS VALVE

Installed in the gas line to control the volume of fuel entering the burner. This controls the heat input, the boiling, and the rate of evaporation within the unit. It can also be connected to the foam sensor to control foaming. *This option available only on XLT and E-900 and larger models.*

INSTALLATION

Installation by factory service technicians or local authorized contractors.

MISCELLANEOUS

Modification of standard equipment for special processes.

**LAKEVIEW ENGINEERED
PRODUCTS INC**

tel: 260-432-3479

fax: 260-432-6239